

SONICA® 45L EP



45
LITRES

General characteristics

Ultrasonic Cleaning is a safe and efficient modern procedure, which ensures perfect cleaning within the shortest time possible. It has many advantages over ordinary cleaning methods. Ultrasonics can remove even the most tenacious deposits from parts which would be difficult to reach by hand, it also reduces the risk of injury or infection which may occur during manual cleaning



Tank Dimensions

Length	500 mm
Breadth	300 mm
Depth	300 mm
Capacity	45 litres

External Dimensions

Length	600 mm
Breadth	340 mm
Height	525mm
Weight	about 21 kg

Constructive Materials

External	Steel AISI 304
Internal	Steel AISI 316Ti 15/10

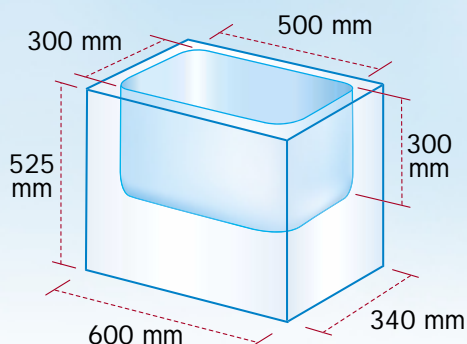

CE EMC 89/336/CEE (EN 55011B)
 LV 73/23/CEE (EN 61010:1)
 MD 93/42/CEE Medical Devices

45
LITRES

SONICA® 45L EP

Technical Data

Main line voltage	230/240 V ~50/60Hz
Main input power/consumption	600 W
Main input power w/heating	1600 W
Peak HF ultrasound power	1200 W
US fequency	40 khz ± 5%
Liquid drain	di serie 1/2"
Transducers	11

Environmental conditions: Temperature

Rel. Hum. 80% up to 31°C. with linear decrease up to 50% at 40°C

Installation category: Class II according to EN 61010

Notes for use as "Medical Devices":

Denomination: Ultrasonic Cleaning Device

UMDNS-nomenclature (ECRI) 14-263

Field of application: cleaning and disinfection of surgical and dental instruments

Classification ((Medical Devices Directive 93/42/EEC, appendix IX):

Class I, Non Active MD, Non Invasive MD, Non Implantable MD

AVAILABLE SERIES



Version EP The most technologically advanced of the SONICA® range: new Sweep system generator; modern digital display control panel windows; degas time setting; cleaning times from 0 to 99 minutes; tank liquid temperature setting up to 70°C; memory for 9 cleaning programmes; **jet program** function to start quickly and easily cleaning cycle.

Technical specification subject to change.



SOLTEC S.r.l. Via Castelbarco, 17 - 20136 Milano (Italy)
 Tel. +39 0258308378 - Fax +39 0258308595
 www.soltec.it - e.mail: info@soltec.it



CERTIFICATO N° 04100 20041419